

# Slicer

Model No.

**SLC-12**



← **SLC-12**

## Features:

- 12" Hardened alloy knife for durability with dual stone knife sharpener
- Removable gravity feed angled chute with safety guard
- Dial provides adjustable slice thickness (0" - 9/16")
- Fully covered electrical and belt drive area
- 1/2 HP fan cooled with thermal overload protection
- Stain resistant anodized aluminum finish
- 120 Volt NEMA 5-15 P
- Moisture proof ON/OFF switch
- Belt driven knife
- Non-slip feet

## Warranty Info:

### One Year

- Parts on entire unit.
- Valid in United States.
- Valid for commercial use only.

### Ninety Day

- Parts & Labor on entire unit.



Revised → **12/22/2023**



**SLC-12**

[www.servware.com](http://www.servware.com)

Phone:(800).768.5953

Fax:(800).976.1299

Front View

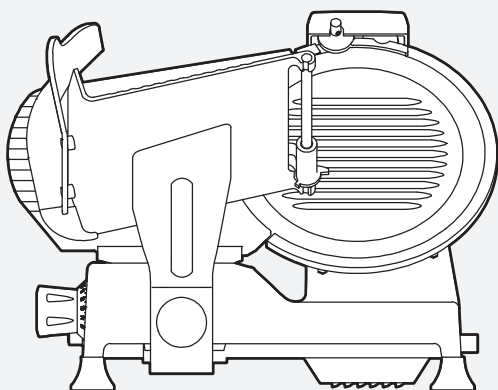

Side View

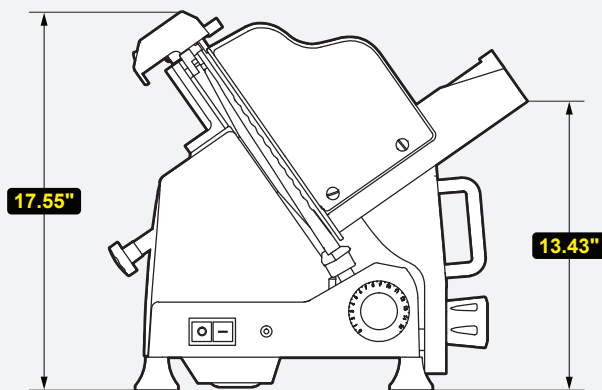

Top View

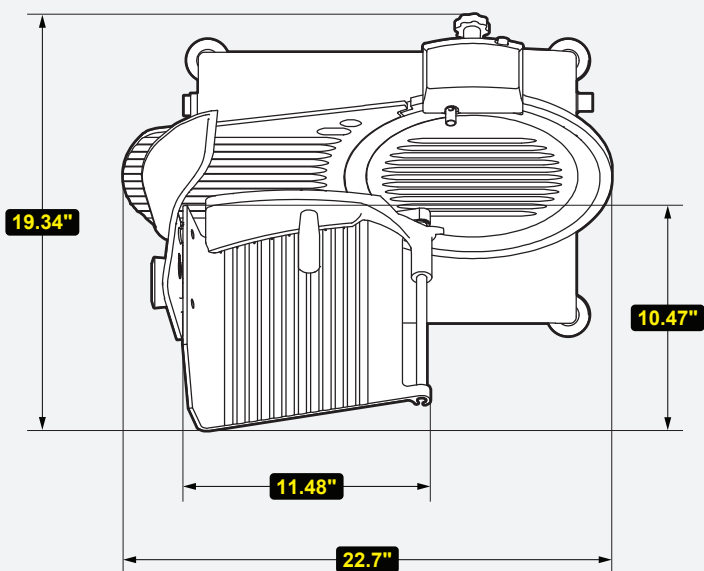

Isometric View

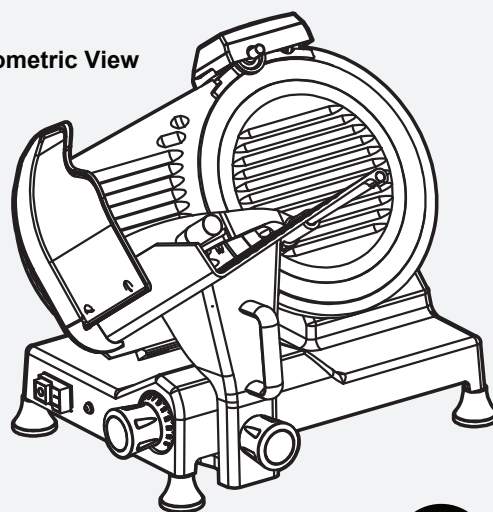

NEMA 5-15P

MODEL #	DESCRIPTION	DIMENSIONS	WEIGHT/LBS.
		(W x D x H)	(Shipping)
SLC-12	Slicer with 12" Blade	22.7" W x 19.34" D x 17.55" H	57 lbs.

CONSTRUCTION	
Stain resistant anodized aluminum construction	

ELECTRICAL	
<b>Voltage</b>	120
<b>Amps</b>	3
<b>Hz</b>	60
<b>Phase</b>	1

ADDITIONAL INFORMATION	
<b>Motor HP</b>	1/3 HP
<b>Drive Type</b>	Belt
<b>Blade Diameter</b>	12 in.
<b>Max Slice</b>	9/16 in.

**Note:** Designed for medium volume continuous use with deli meats. NOT suitable for slicing cheese, frozen or raw meat.



Prop. 65 Warning for California Residents  
 WARNING: This product may contain chemicals known to the State of California to cause cancer, birth defects, or other reproductive harm.



Phone:(800).768.5953  
 Fax:(800).976.1299

## SLC Series - Food Slicer

**Notify carrier of damage! Inspect all components immediately.**

*Serv-Ware Products warrants to the original owner/user that any product manufactured shall be free of defects in material or workmanship, under normal use and maintenance, for a period of one (1) year from the original installation date or a maximum of eighteen (18) months after the shipment date from Serv-Ware Products. Proper installation and start-up in accordance with the instruction manual supplied will be taken into consideration when evaluating the warranty on the specified equipment.*

*The ninety (90) day labor warranty shall include standard labor charges at the product location only. The end user is responsible for any emergency, overtime, or long-distance travel charges. Any labor service required to fulfill the warranty obligation must be performed by a qualified commercial food equipment service company and accepted by Serv-Ware Products. Billing will be handled between the service company and manufacturer directly, there will be no compensation for charges not billed to Serv-Ware Products by the service company. Serv-Ware Products reserves the right to have any warranty "failed" parts returned to the factory for inspection before agreeing to covering the above stated warranty labor charges.*

### **This warranty does not include parts & labor coverage resulting from:**

- External electrical power failure or improper supply voltage to product.
- Adverse operating conditions for the product.
- Failure to clean and/or maintain the product.
- Standard wear & tear items.
- Damage that is caused by employees or customers.
- Any part or assembly that has been altered, modified, or changed.
- Equipment usage in a residential or non-commercial setting.

### **LIMITATION OF LIABILITY AND OTHER WARRANTIES**

*Serv-Ware Products assumes no liability for misuse or inadequate maintenance of the Product. In no event shall the user be entitled to recover incidental or consequential damages. Including but not limited to; damages for inconvenience, food loss, rental or replacement equipment, loss of profits, or other commercial loss.*

*Warranties stated above are the only warranties made in connection with the sale and distribution of the Products. ANY AND ALL OTHER EXPRESSED STATUTORY AND IMPLIED WARRANTIES APPLICABLE TO THE PRODUCT INCLUDING, WITHOUT LIMITATION, ALL IMPLIED WARRANTIES OF MERCHANTABILITY AND FITNESS FOR USE ARE EXPRESSLY DISCLAIMED. The warranty information set forth above shall be governed by and construed in accordance with the laws of the State of North Carolina and, if applicable, the laws of the United States of America. The warranty, as stated, is extended only to the original owner/user and is not assignable. Serv-Ware reserves the right to change product specifications without notice due to constant product improvement.*