

Warmer Drawer



Model No.

SWPWDS-2**SWPWDS-2**

Features:

- Heavy duty stainless steel construction with 1" thick fiberglass for maximum insulation.
- 11 gauge stainless steel drawer slides with 14 gauge slide brackets makes the drawer jam free.
- Adjustable "pan supports" accommodates **included** standard size pans (12" x 20" x 4") and various other pan sizes.
- Each drawer individually controlled by LED digital temperature controls to accurately monitor the temperature, indicator lamp and vent controls.
- Indicator lamp and vent controls included.
- Temperature range of 80° - 220°F.
- Consistent temperatures are achieved due to the unique heating system so food will remain moist and flavorful longer.
- Available in 1-drawer, 2-drawer, and 3-drawer freestanding models.

Warranty Info:

One Year

- Parts & Labor on entire unit.
- Valid in United States.
- Valid for commercial use only.

Revised **04/20/2023****SWPWDS-2**www.servware.com

Phone:(800).768.5953

Fax:(800).976.1299

SWPWDS-2 Warmer Drawer



Item # _____
 Project : _____
 Qty : _____

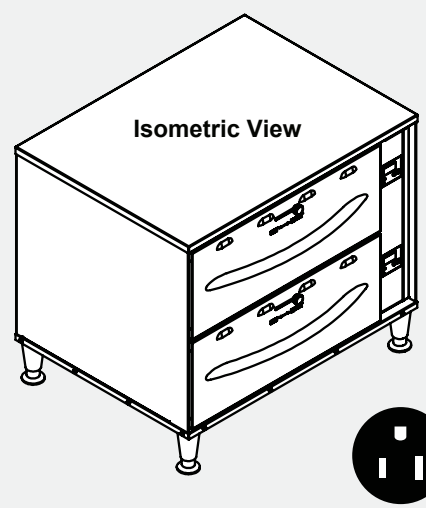
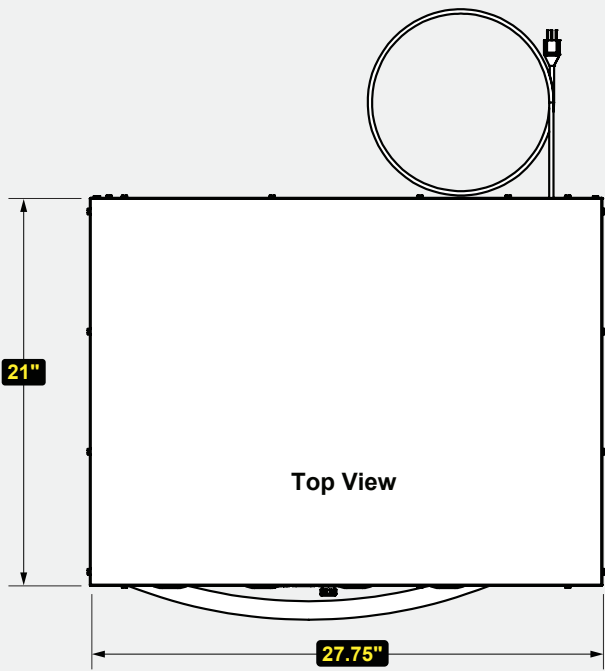
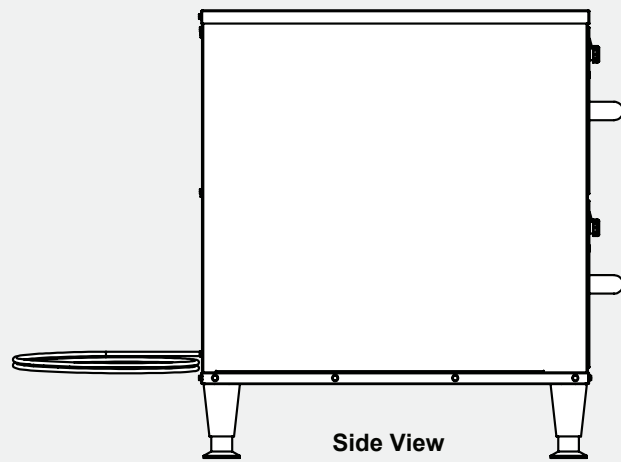
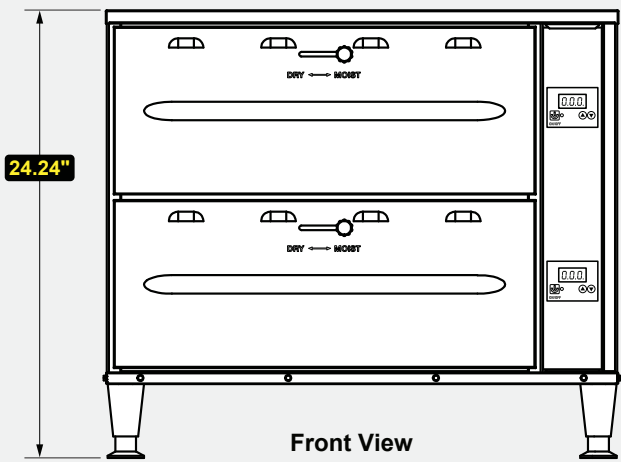

NEMA 5-15P

➤ Technical Information:

MODEL #	DESCRIPTION	DIMENSIONS (W x D x H)	WEIGHT/LBS. (Shipping)
SWPWDS-2	2 Drawer-Warmer	27.75" W x 21" D x 24.24" H	175 lbs.

CONSTRUCTION
Heavy duty stainless steel construction with 1"thick fiberglass for maximum insulation.
Two drawer.

ELECTRICAL
Voltage 120
Amps 7.5
Hz 60
Watts 900
Phase 1

WARMING
Temperature Range 80°F – 220°F
LED Temp. Control Each Drawer
Stainless Steel PAN (Included)
Standard Size 12" x 20" x 4"
Each Drawer



Prop. 65 Warning for California Residents
 WARNING: This product may contain chemicals known to the State of California to cause cancer, birth defects, or other reproductive harm.



Phone:(800).768.5953
 Fax:(800).976.1299

Copyright © 2023 Serv-Ware Products LLC

www.servware.com

SWPWDS Series - Warmer Drawer

Notify carrier of damage! Inspect all components immediately.

Serv-Ware Products warrants to the original owner/user that any product manufactured shall be free of defects in material or workmanship, under normal use and maintenance, for a period of one (1) year from the original installation date or a maximum of eighteen (18) months after the shipment date from Serv-Ware Products. Proper installation and start-up in accordance with the instruction manual supplied will be taken into consideration when evaluating the warranty on the specified equipment.

The labor warranty shall include standard labor charges at the product location only. The end user is responsible for any emergency, overtime, or long-distance travel charges. Any labor service required to fulfill the warranty obligation must be performed by a qualified commercial food equipment service company and accepted by Serv-Ware Products. Billing will be handled between the service company and manufacturer directly, there will be no compensation for charges not billed to Serv-Ware Products by the service company. Serv-Ware Products reserves the right to have any warranty "failed" parts returned to the factory for inspection before agreeing to covering the above stated warranty labor charges.

This warranty does not include parts coverage resulting from:

- External electrical power failure or improper supply voltage to product.
- Adverse operating conditions for the product.
- Failure to clean and/or maintain the product.
- Standard wear & tear items.
- Damage that is caused by employees or customers.
- Any part or assembly that has been altered, modified, or changed.
- Equipment usage in a residential or non-commercial setting.

LIMITATION OF LIABILITY AND OTHER WARRANTIES

Serv-Ware Products assumes no liability for misuse or inadequate maintenance of the Product. In no event shall the user be entitled to recover incidental or consequential damages. Including but not limited to; damages for inconvenience, food loss, rental or replacement equipment, loss of profits, or other commercial loss.

Warranties stated above are the only warranties made in connection with the sale and distribution of the Products. ANY AND ALL OTHER EXPRESSED STATUTORY AND IMPLIED WARRANTIES APPLICABLE TO THE PRODUCT INCLUDING, WITHOUT LIMITATION, ALL IMPLIED WARRANTIES OF MERCHANTABILITY AND FITNESS FOR USE ARE EXPRESSLY DISCLAIMED. The warranty information set forth above shall be governed by and construed in accordance with the laws of the State of North Carolina and, if applicable, the laws of the United States of America. The warranty, as stated, is extended only to the original owner/user and is not assignable. Serv-Ware reserves the right to change product specifications without notice due to constant product improvement.