

SERV-WARE™

Stainless Steel Overshelf

SPOS-48

For Sandwich Prep Table
SP48-12-HC

SPOS-60

For Sandwich Prep Table
SP60-16-HC

Assembly & Installation Guide

For questions, contact the Service department at:
service@servware.com or
call 800-768-5953

ASSEMBLY PARTS LIST

1 1 pc

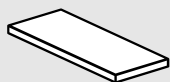

2 4 pcs



3 1 pc

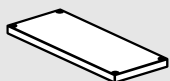

4 2 pcs

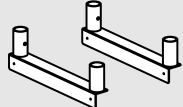

5 12 pcs

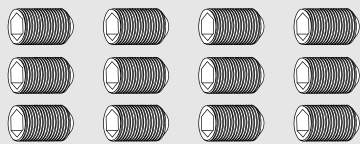

- 1 Top Shelf
- 2 Shelf Support Legs
- 3 Middle Shelf
- 4 Bracket Attachments
- 5 Set Screws

STEP 1

Install 2 Legs (4 pcs) into 1 Top (1 pc).
Use 5 Set Screws (4 pcs) & tighten.

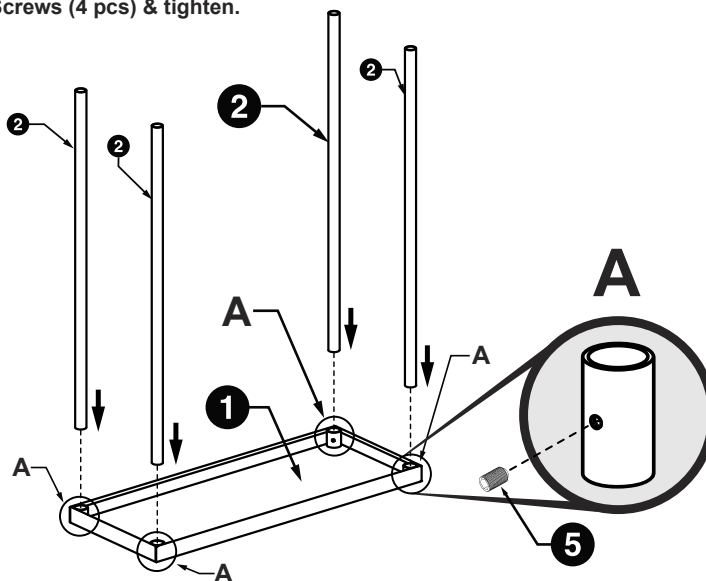

STEP 2

Install 3 shelf (1 pcs) into 2 Legs.
Use 5 Set Screws (4 pcs) adjust to preferred height & tighten.

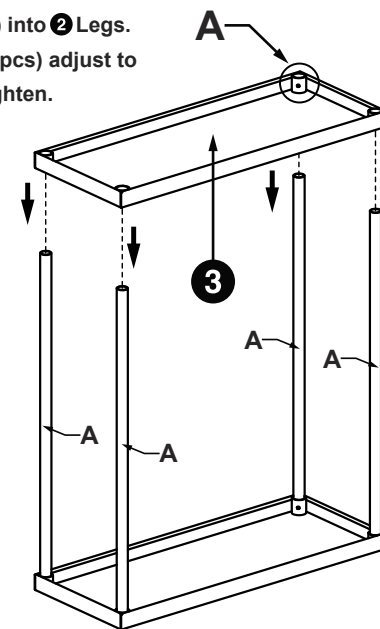

STEP 3

Install 4 Bracket Attachments (2 pcs) into 2 Legs.
Use 5 Set Screws (4 pcs) & tighten.

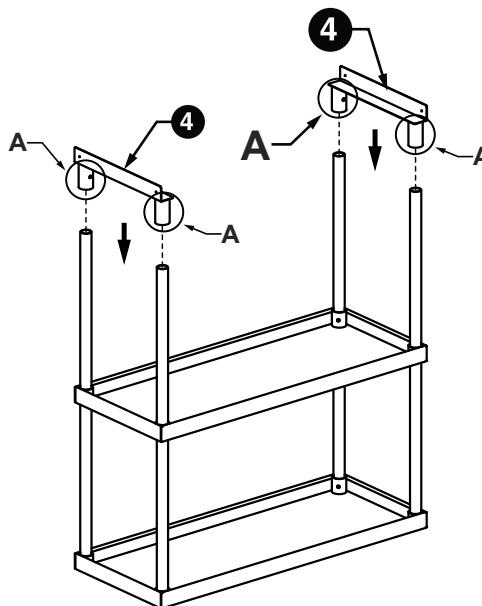

FINAL ASSEMBLY

It is recommended to use a level on the middle shelf.

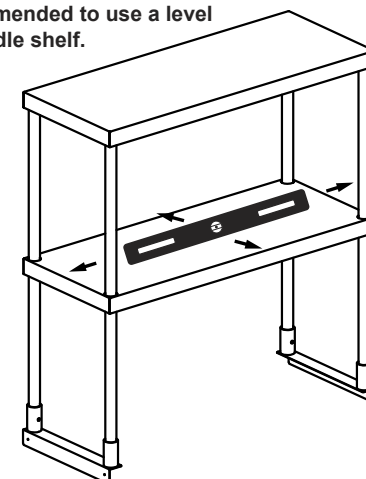

ASSEMBLY TOOL LIST

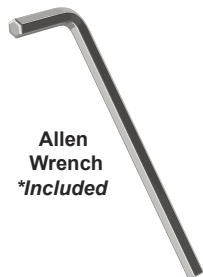

Allen Wrench
*Included



Level

SERV-WARE™

Stainless Steel Overshelf

SPOS-48

For Sandwich Prep Table
SP48-12-HC

SPOS-60

For Sandwich Prep Table
SP60-16-HC

Assembly & Installation Guide

For questions, contact the Service department at:
service@servware.com or
call 800-768-5953

INSTALLATION PARTS LIST

A 1 pc

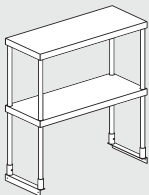

B 1 pc

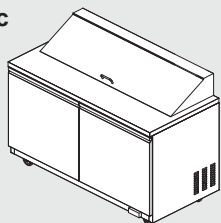

C
4 pc



A Top Shelf Assembled **B** Sandwich Prep Unit

C Sheet Metal Screws (4 pcs)

INSTALLATION TOOL LIST

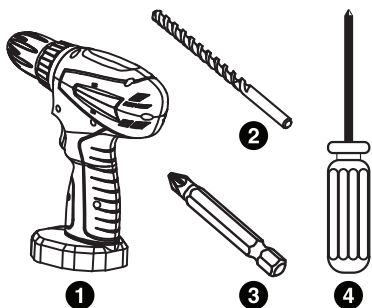

1 Drill **2** Drill Bit **3** Phillips Bit

4 Phillips Screwdriver (* Optional)

STEP 1

To install Assembled **A** Top Shelf, lift & align over the Sandwich Prep Unit as shown. It is recommended to have one or more persons to help hold & align the **A** Top Shelf before drilling four holes to fasten **C** sheet metal screws.

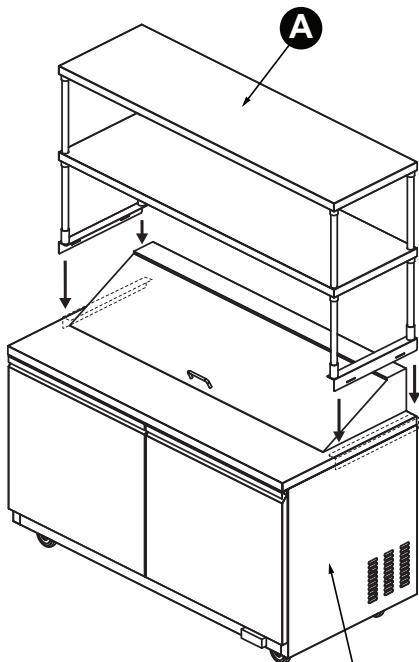

STEP 2

Once the Top Shelf is aligned correctly use a **1** drill & **2** drill bit to make 4 screw holes. Carefully drill through outside panel making sure not to puncture through to the inner panel. (*Self tapping screws may also be used if preferred.)

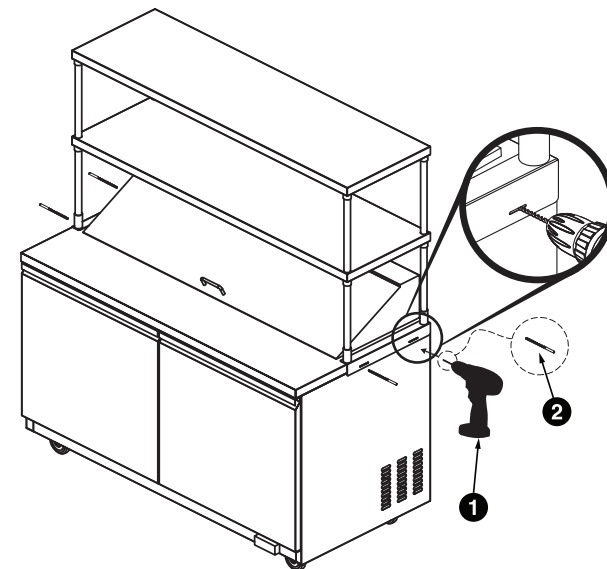

FINAL INSTALLATION

STEP 3

Carefully screw in **C** sheet metal screws to avoid stripping screws and tighten to secure top shelf to unit. Adjust middle shelf so unit's top hatch opens for easy access.

